

**TENERGY®**

PN 59151

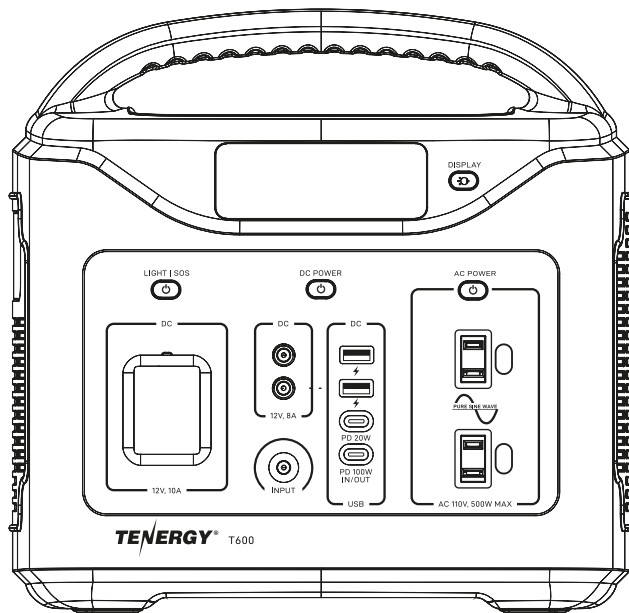

**T600**

# POWER STATION

USER GUIDE



## **CHARGE ME NOW**

Before using or storing, plug your Tenery T600 unit into the wall until it is fully charged.

# IMPORTANT SAFETY INSTRUCTIONS

## WARNING

When using this product, basic precautions should always be followed, including the following:

- a) Read all the instructions before using the product.
- b) To reduce the risk of injury, close supervision is necessary when the product is in use near children.
- c) Do not put fingers or hands into the product.
- d) Use of an attachment not recommended or sold by power pack manufacturer may result in a risk of fire, electric shock, or injury to persons.
- e) To reduce risk of damage to the electric plug and cord, pull the plug rather than the cord when disconnecting the power pack.
- f) Do not use a battery pack or appliance that is damaged or modified. Damaged or modified batteries may exhibit unpredictable behavior resulting in fire, explosion or risk of injury.
- g) Do not operate the power pack with a damaged cord or plug, or a damaged output cable.
- h) Do not disassemble the power pack; take it to a qualified service person when service or repair is required. Incorrect reassembly may result in a risk of fire or electric shock.
- i) To reduce the risk of electric shock, unplug the power pack from the outlet before attempting any instructed servicing.
- j) When charging the internal battery, work in a well ventilated area and do not restrict ventilation in any way.
- k) Under abusive conditions, liquid may be ejected from the battery; avoid contact. If contact accidentally occurs, flush with water. If liquid contacts eyes, seek additional medical help. Liquid ejected from the battery may cause irritation or burns.
- l) Do not expose power pack to fire or excessive temperature. Exposure to fire or temperature above 130°C (265°F) may cause explosion.
- m) Have servicing performed by a qualified repair person using only identical replacement parts. This will ensure that the safety of the product is maintained.

**SAVE THESE INSTRUCTIONS**

## TABLE OF CONTENTS

<b>WHAT'S IN THE BOX</b> .....	1
<b>GET TO KNOW YOUR UNIT</b> .....	1
<b>HOW IT WORKS</b> .....	2
<b>CHARGING YOUR UNIT</b> .....	3
<b>USING YOUR UNIT</b> .....	4-8
<b>STORAGE &amp; MAINTENANCE</b> .....	9
<b>TECHNICAL SPECIFICATIONS</b> .....	9
<b>FAQS &amp; TROUBLESHOOTING</b> .....	10-11
<b>WARRANTY</b> .....	12
<b>CONTACT US</b> .....	13

## WHAT'S IN THE BOX

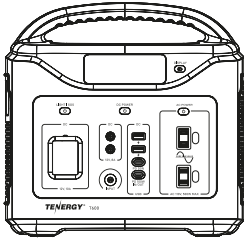

Tenergy T600

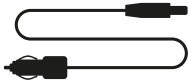

Car Charger





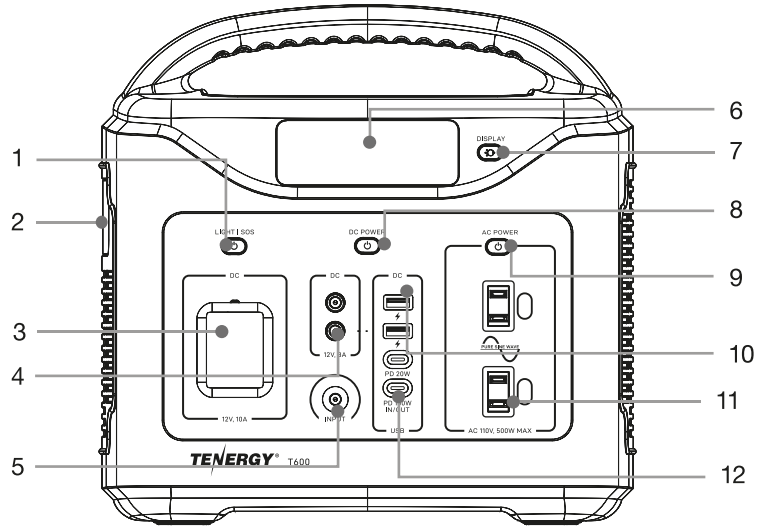

Wall Adapter

## GET TO KNOW YOUR UNIT









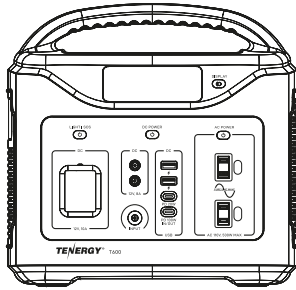





- |                       |                    |                    |
|-----------------------|--------------------|--------------------|
| 1. LED light button   | 5. Input port      | 9. AC power button |
| 2. LED light          | 6. LCD screen      | 10. USB ports      |
| 3. 12V, 10A DC output | 7. LCD on/off      | 11. AC outlets     |
| 4. 12V, 8A DC outputs | 8. DC power button | 12. USB-C ports    |

## 4 WAYS TO RECHARGE

-   
AC Adapter  
7 hours
-   
USB-C  
7 hours\*
-   
Car Charger  
12 hours
-   
Solar Panel  
8 hours\*



## WHAT IT POWERS

-   
Phone  
60 Charges
-   
LED Light (5W)  
52 Hours
-   
Tablet  
17 Charges
-   
Fridge/Cooler  
40 Hours
-   
Laptop  
8 Charges
-   
Electric Blanket  
25 Hours
-   
Drone  
10 Charges
-   
Heated Mugs  
11 Charges
-   
Game Console  
35 Hours
-   
TV/Projector (60W)  
8.5 Hours
-   
CPAP  
10 to 45 Hours
-   
Camera  
40 Charges

\*USB-C PD charger and solar panel sold separately.  
Actual solar charging time varies, depending on conditions.

\*Combined Inputs Charging: Use the AC adapter and USB-C inputs at the same time to reduce charging time.

## CHARGING YOUR UNIT

### Charge through AC adapter

Connect your T600 unit to the wall outlet with the AC adapter that comes with your portable power station packaging. The LCD display will indicate when the power station is being recharged.

### Charge through your car

Connect your T600 unit to your 12V car cigarette lighter socket with the car charger that comes with your portable power station packaging. The LCD display will indicate when the power station is being recharged.

### Charge through solar panel (sold separately)

Place your solar panel where it can get the strongest direct sunlight. Connect the solar panel's output port with the T600's input port. The LCD display will indicate when the power station is being recharged.

\*Compatible with solar panels with output voltage of 11.1V-23.4V.

#### MPPT technology:

With MPPT (maximum power point tracking) technology, T600 tracks the max wattage provided by solar power and becomes more efficient at converting energy into power to recharge the power station.

### Charge through USB-C charger (sold separately)

Connect your T600 unit to another USB-C PD charger with a USB-C cable with power delivery (both the USB-C cable and adapter are sold separately), via the 100W USB-C port on the T600 unit. The LCD display will indicate when the power station is being recharged.

\*Protip: Combine the USB-C charging with the AC input to speed up the charging process.

## USING YOUR UNIT

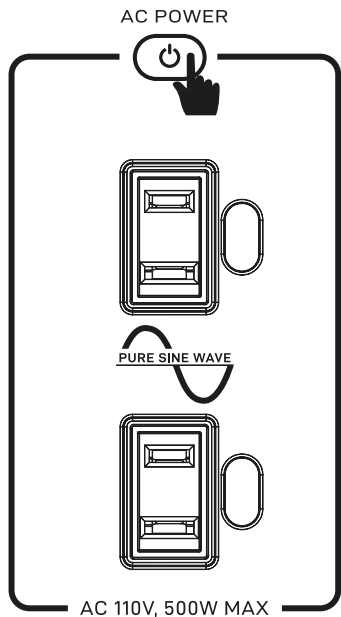

### Powering AC applications

- 1 Connect your AC application to the T600.
- 2 Press the AC power button to turn on AC power output. The AC icon will display on the LCD screen to indicate that it is enabled.
- 3 Press the AC power button again to shut off AC output.

#### NOTE:

When not in use, be sure the AC output is off. The AC power button LED light will be off.

#### WARNING: AC!

Ensure that the total wattage of all AC devices simultaneously plugged into the AC outlets not exceed 500 watts. If overloading occurs, please remove the overloaded application, and press the power button to reset the unit.



## USING YOUR UNIT

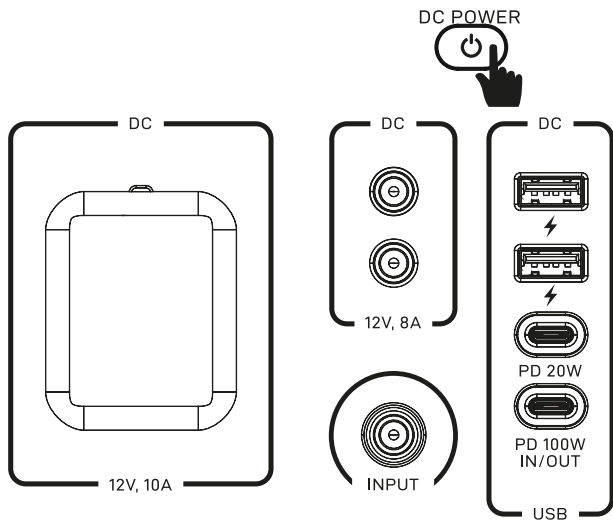

### Powering DC applications

- 1 Connect your DC application to the T600 via any of the DC output ports (USB, USB-C, DC socket, car port) that fits your application connector.
- 2 Press the DC power button to enable DC power output, the DC icon will display on the LCD screen to indicate that it is enabled.
- 3 Press the DC power button again to shut off the DC output.

#### **NOTE:**

The USB-C PD100W IN/OUT port is equipped with a wake-up feature, which does not require the user to press the "DC Power" button before usage. To charge/recharge via the PD100W port, just connect the T600 with your device with a compatible USB-C to USB-C cable to use it.

## USING YOUR UNIT

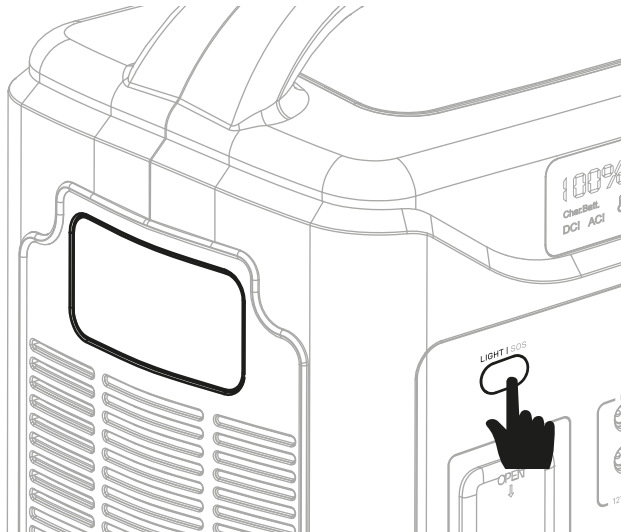

### Using the built-in LED light

- 1 Press the light button once to turn on the built-in LED at full brightness. Press the for the second time to turn set the light to 50% brightness. Press the button for the third time to turn it off.
- 2 Press and hold the light button to output lights in a SOS distress pattern and to signal danger to others. Press the button again to turn it off.

## USING YOUR UNIT

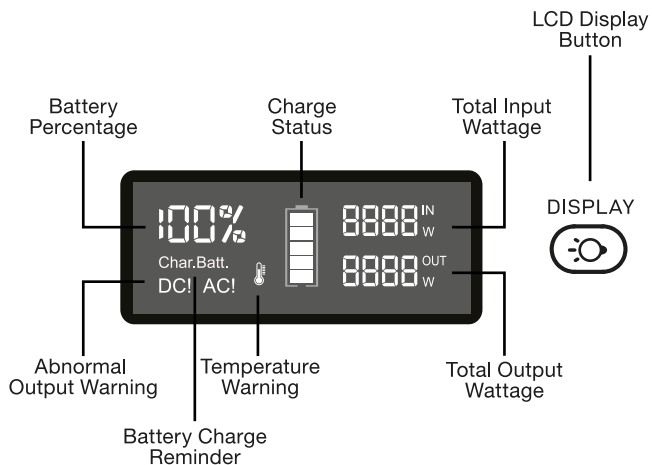

### LCD icons:

#### AC! Abnormal Output Warning

This icon indicates the power draw for the output ports is more than the power station can supply. Please unplug an application to balance the load again.

#### DC! Abnormal DC Output Warning

This icon indicates the power draw for the DC output ports is more than the power station can supply, or short circuited. Please unplug an DC application to balance the load again.

#### Char.Batt.

#### Battery Low Voltage Warning

Please recharge the power station.



#### Temperature Warning

This icon indicates that the power station is overheating. Please take actions to cool the unit off. Such as unplugging and stopping all devices drawing power, or moving the power station to a cooler shady location.

DISPLAY



#### LCD Display Button

This button turns the LCD display screen off and on.

## USING YOUR UNIT

### Auto turn-off function

To save energy and to prolong the battery life, the T600 has equipped with an auto turn-off function that is activated by default; that if the load of the AC application(s) has been low enough for 10 hours; the T600 will auto turn itself off.

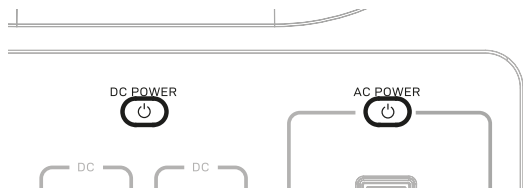

### Manually overriding the auto turn-off function:

The auto turn-off function can be manually disabled. To allow low applications that draw 3W or less to run, follow these steps:

- 1 Press and hold BOTH DC power button and AC power button for 3 seconds.

- 2 T600 will make 2 short beeps to indicate that auto turn-off has been disabled. Then let go of your fingers.
- 3 You can now use the T600 to power low wattage AC applications without interruptions.

### Reactivate auto turn off after manual over ride:

Auto turn-off function can be reactivated after a manual over ride. To reactivate auto turn-off:

- 1 Press and hold BOTH DC power button and AC power button for 3 seconds.
- 2 T600 will make 1 long beep to indicate that auto turn-off has been reactivated. Then let go of your fingers.
- 3 This power saving auto turn-off function is now active again.

#### NOTE:

The auto turn-off function is automatically enabled when the T600 is turned off and on again. Regardless of the previous settings, this feature will be enabled when the device is powered off and on again.

## STORAGE & MAINTENANCE

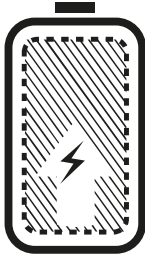

### CHARGE BEFORE STORING

Do not store your T600 at low power level.

Charge it immediately after your adventures to prevent damage to the battery.

Always fully-charge your T600 unit before putting it to storage. Store it in a cool, dry place.

To prolong battery life and ensure your unit is always ready to use, check the battery level frequently and fully recharge it every 3 to 6 months.

## TECHNICAL SPECIFICATIONS

Model NO.	T600	
Battery Cell	Lithium-ion (LiFePO <sub>4</sub> )	
Capacity	600Wh (19.2V, 31.25Ah)	
Input	DC 20V 5A with MPPT support	
AC Output	2x 110V ~ 4.5A, 60Hz, 500W	
DC Output	2x DC 12V	10A, 120W
	1x Car Port 12V	
	2x USB 5V  2.4A, with QC3.0 support	
Temperature	1x USB-C PD, 100W; 1x USB-C PD, 20W	
	Operating	14°F to 104°F
	Recharging	32°F to 104°F

## FAQS & TROUBLESHOOTING

### **Q: Can I use output ports when T600 is charging?**

A: Yes you can.

### **Q: How long will this power station run my device?**

A: Runtime hours depend on typical power consumption (how many watt) your application requires. Find the typical power consumption of your device from its manufacturer, and then divide 600 times by the typical wattage consumption. For example: a CPAP machine has a typical power consumption of 53W,  $600 / 53 = 11.3$  hours. A fully charged T600 can run this CPAP machine for about 11.3 hours per charge. Note: Different kinds of application will have different conversion rate, actual runtime can vary by 15%.

### **Q: What kind of solar panel is compatible?**

A: Any solar panel with 11V ~ 23.4V DC output will provide enough charging voltage to charge your T600 unit via solar. But for significant charging speed, we recommend solar panels of at least 100W.

### **Q: Why does T600 keep turning itself off from time to time when powering my small applications?**

A: Most likely caused by the wattage of your application is too low and triggered the auto turn off feature. To keep your low-wattage application running without interrupting. Please manually turn off the auto turn off feature (see page 8).

### **Q: Why can't I use it power my coffee maker?**

A: Typical coffee maker has power of 800+watts. Which is higher than the 500watt AC output limitation of T600. Same idea for other applications such as air dryer, heater, cooker, or anything excess 500Watts.

### **Q: It will not stay on even it still has N% left.**

A: (1) Using the unit in high temperature locations may make the unit running hot, and has its over temperature protection triggered even when it still has power in it. Do not use this unit under direct sun when the weather is hot, keep it in the shade and keep it well ventilated will help with lowering the temperature. (2) Also, the % display may not be totally accurate if it has been stored for a while without usage; to recalibrate the %, simply recharge the unit back to 100%.

### **Q: Is the battery replaceable?**

A: The internal battery is not replaceable, but if it's maintained well, it can be recharged for up to 2000 times. Which provides a very long life span.

### **Q: Can I keep the unit plugged to AC power?**

A: It's not recommended, as it will slightly reduce the life span of the unit over time, however, if you find it difficult to charge the unit when its power level is low. Or you plan to put it in storage for over a year without charging. Keeping it plugged into the AC power while storing is doable to prevent over discharge.

## FAQS & TROUBLESHOOTING

### **Q: Can I take the T600 on an airplane?**

A: Due to current transportation regulations, you cannot. Please call the respective of airline to check before you took it to airport. Inform them it's a lithium-ion battery of 600 watt-hours, and ask for confirmation on compliance.

### **Q: "AC!" or "Temperature" icon shows up on the screen, and it's not working.**

A: This can mean one or more of the following issue:

Over load protection: remove the overloaded application that plugged onto T600, press the power button to reset the unit.

Short circuit: same as over loading, remove application and press the power button to reset.

Over heat protection: let the unit cool down a few minutes, then press the power button and see if gets back to normal condition. If not, give it another few minutes.

### **Q: The USB-C PD port is not inputting / outputting 100W as advertised.**

A: (1) Make sure your device/charger supports 100W USB-C PD charging speed. (2) Make sure your USB C-to-C cable is designed for 100W high-speed charging.

### **Q: I tried everything but it's still not working or not meeting my needs.**

A: Please contact our customer service team for further assistance.

## **MORE QUESTIONS?**

Feel free to contact our customer service specialist:



**510-979-9969**



**service@tenergy.com**

## WARRANTY

### LIMITED WARRANTY

TENERGY warrants this TENERGY product under normal consumer use during the applicable warranty period identified in “WARRANTY PERIOD” below, subject to the exclusions set forth in “EXCLUSIONS” below. This warranty statement sets forth TENERGY’s total and exclusive warranty obligation. We will not assume, nor authorize any person to assume for us, any other liability in connection with the sales of our products.

### WARRANTY PERIOD

The warranty period is 24 months. The warranty period is measured starting on the date of purchase by the original consumer purchaser. The sales receipt from the first consumer purchase, or other reasonable documentary proof, is required in order to establish the start date of the warranty period.

### REMEDY

TENERGY will repair or replace (at TENERGY’s option) any TENERGY product that fails to operate during the applicable warranty period due to a defect in workmanship or material.

### LIMITED TO ORIGINAL CONSUMER BUYER

The warranty on TENERGY’s products is limited to the original consumer purchaser and is not transferable to any subsequent owner.

### EXCLUSIONS

TENERGY’s warranty does not apply to (i) any product that is misused, abused, modified, damaged by accident, or used for anything other than normal consumer use as authorized in TENERGY’s current product literature, or (ii) any product purchased through an online auction house. TENERGY’s warranty does not apply to any battery cell or product containing a battery cell unless the battery cell is fully charged by you within seven days after you purchase the product and at least once every 3 months thereafter.

### HOW TO RECEIVE SERVICE

To obtain warranty service, you must contact our customer service team via telephone at **510- 979-9969**, or via email at **[service@tenergy.com](mailto:service@tenergy.com)**.



## CONTACT US



**510-979-9969**

Mon-Fri 9am-5pm PST (US)



**service@tenergy.com**



**power.Tenergy.com**

LIVE CHAT

**THANK YOU!**